

Sentinel Connector Systems Inc.

1953 Stanton Street
York, Pa. 17404

PART NO.: B00055L

- * FOR USE WITH SPECIFIC LOAD BAR STYLE RJ-45 PLUGS
- * OPENING TO ACCEPT CABLES TO 6.7mm
- * THIS PART IS CLEAR IN COLOR
- * THIS PART HAS NO LOGO

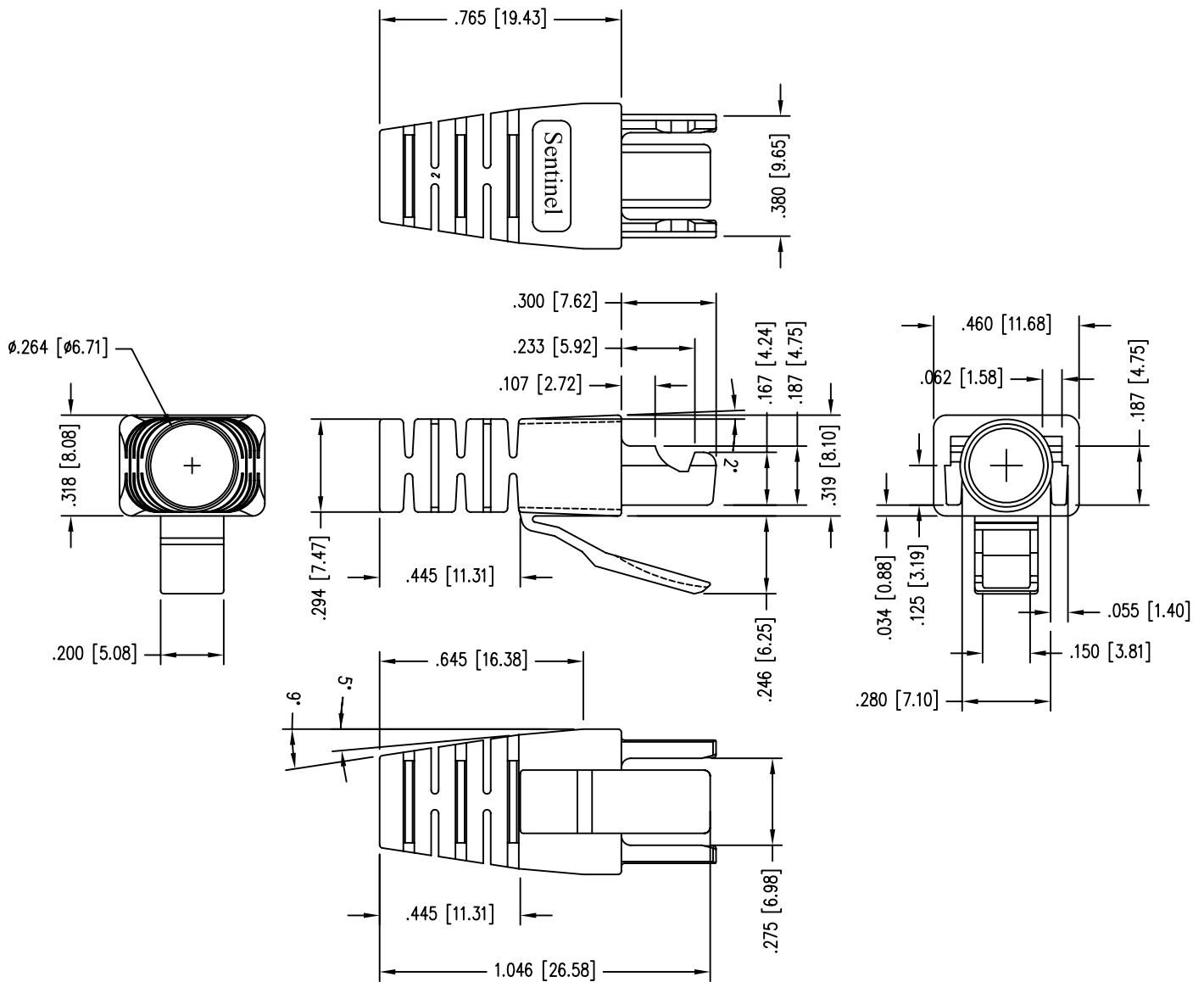
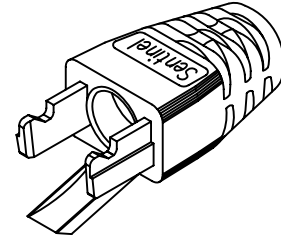

SPECIFICATIONS:

MATERIAL: _____ POLYCARBONATE - V0
 OPERATING TEMPERATURE: _____ -40° TO +70° C
 U.L. RECOGNIZED File# E188111
 FLAME AUTO EXTINGUISH 94-V0